

Hinged-shaped safety switches in stainless steel, HX series



Application field

Pizzato Elettrica widens its own range of products making a new series of safety switches hinge-shaped HX series, where safety and style are melted in one single product.

The switch is completely integrated in the mechanical hinge, to result practically invisible to an inexperienced eye. This guarantees a higher safety because a switch hard to identify is consequently also more difficult to defeat. The assembly without visible screws and the pleasant line, make the switch perfectly integrated also with guards of modern design machinery.

The hinge-shaped safety switches of the HX series, being made of stainless steel, can be used in any aseptic environment where particular attention is required for cleanliness and hygiene, therefore they are suitable for various applications ranging from the food to the pharmaceutical sectors, as well as the chemical or marine sector.



Operating point regulation



The switches operating point can be regulated through a simple Phillips screwdriver. The operating point regulation allows the setting possibility for large guards. After the setting, it's always necessary to close the hole through the suitable supplied safety seal plug.

Variations of the activation base angle



New versions with the switch activation angle equal to a multiple of 15° (e.g. 45° or 90°) are available on request.

The different activation angle does not exclude the possibility of finely adjusting the operating point by means of the adjustment screw found in the switch. Any change in the base operating angle does not alter the maximum mechanical switch travel.

Cable with connector from the back



The version with a rear cable and M12 connector is used to obtain the best combination between aesthetics and connection ease. This solution makes it possible to hide the wiring and, at the same time, easily connect or disconnect it from inside the machinery.

Opening angle up to 180°



The mechanical design of the switch allows the application also onto protections up to 180° opening angle.

Protection degree IP67 and IP69K

IP69K IP67

The HX series switches by Pizzato Elettrica, besides having an IP67 protection degree, have passed the test proving their IP69K protection degree according to the prescriptions established by the DIN 40050 standard. Therefore they are suitable for use in machineries

subjected to intense washing with high pressure and high temperature water jets and for any condition or environment where a particular attention for cleanliness and hygiene is required, such as in food or pharmaceutical industry.

Additional hinges



To complete installation, various types of additional hinges are available, varying in numbers depending on the protection guard weight. These hinges keep the same aesthetics and mechanical structure but, having no electrical part, they cost less.

Materials

AISI 316L

With this new series in AISI316L stainless steel, Pizzato Elettrica offers a range of devices suitable for any environment where chemical and corrosive agents are found or for aseptic environment where particular attention is required for cleanliness and hygiene. Accurate surface finish makes it possible for these devices to be used in various applications ranging from the food to the pharmaceutical sectors, as well as the chemical or marine sector.

Laser marking



Pizzato Elettrica has introduced a new laser marking for switches of the HX series. Thanks to this new system which excludes the use of labels, markings on the products are indelible.

Furthermore, in case of machineries subjected to intense high pressure water jets, there is no risk of labels detaching from the product.

Version with electronic contacts (PL e / SIL 3)



The redundant internal structure of the HX hinged safety switch meets the characteristics required by the EN ISO 13489-1 and IEC 62061 standards, therefore the actual switch can be classified as a device of category 4, PL e and SIL 3.

Its high diagnostic cover and high MTTF for each single channel make it possible for the HX switch not to lose its safety function even in the case of one single anomaly.

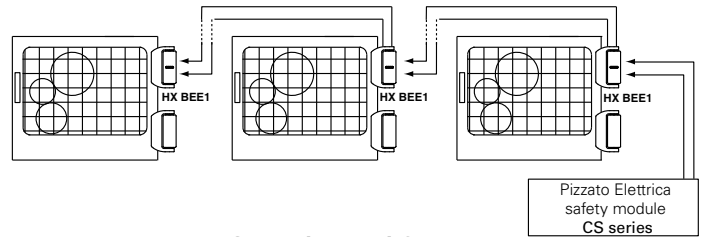

These are the reason why the switch can be used in series, while maintaining the PL e safety level, as long as it is connected to an appropriate module which controls its correct operation.

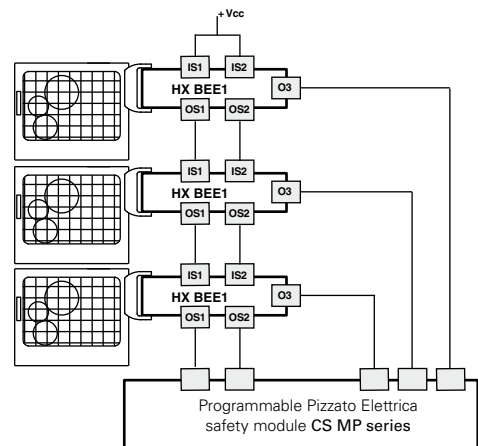
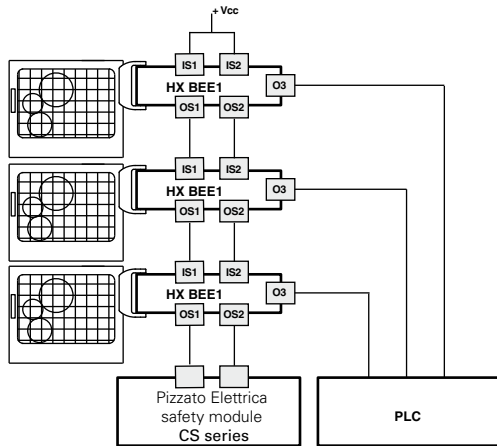

Possible connection in series of several switches in order to simplify the safety system wiring, after evaluating the outputs from the last switch in the chain by means of a Pizzato Elettrica safety module (table for safety modules to be combined). Each HX switch is provided with a signalling output, which is activated when the respective guard is closed. This piece of information can be managed by a PLC, depending on the specific requirements of the system installed.

Possible connection in series of several switches in order to simplify the safety system wiring, after evaluating the outputs from the last switch in the chain by means of a safety module from Pizzato Elettrica CS MP series, which allows management of both safety and signalling functions.

Switch	Compatible safety modules	Safety module output contacts		
		Safety instantaneous contacts	Safety delayed contacts	Signaling contacts
HX B.....	CS AR-05.....	3NO	/	1NC
	CS AR-06.....	3NO	/	1NC
	CS AR-08.....	2NO	/	/
	CS AT-0.....	2NO	2NO	1NO
	CS AT-1.....	3NO	2NO	/
	CS MP.....	see article features		

Internal diagram

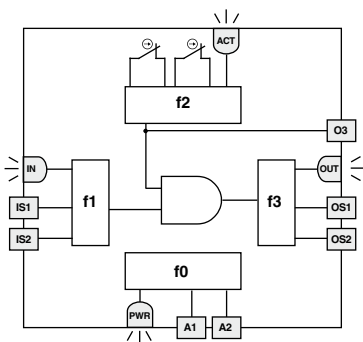

The side scheme shows the 4 logical functions interacting inside the switch.

F0 function has the fundamental task to control the sensor's power supply and the internal tests which the sensor cyclically undergoes.

F1 function has the task to control the status of the sensor's inputs, while F2 checks the actuator's presence within the activation zone limits.

F3 function has the task to

enable the safety outputs and check their possible failure or short circuit. The macro-function, which controls the above mentioned functions, enables the safety outputs only in presence of active inputs with the actuator within the safe zone limits.

4 status-indicator LEDs



The version with electronic contacts in the HX series is provided with 4 LEDs which make it possible to quickly identify the status it is found in. Each LED is assigned a specific signalling function which makes it possible to immediately identify any wiring errors, circuit breaks or internal faults in the device. The status of each function is displayed by the corresponding LED (PWR, OUT, IN, ACT,), so that the switch condition becomes immediately evident to the operator. This avoids the need to decode troublesome blinking sequences in order to identify specific system faults.

Selection diagram

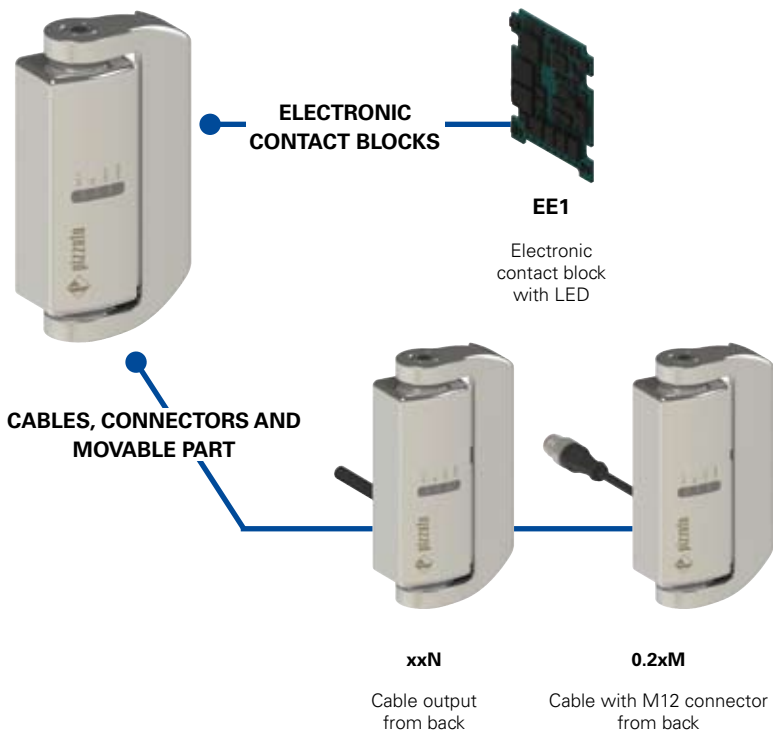
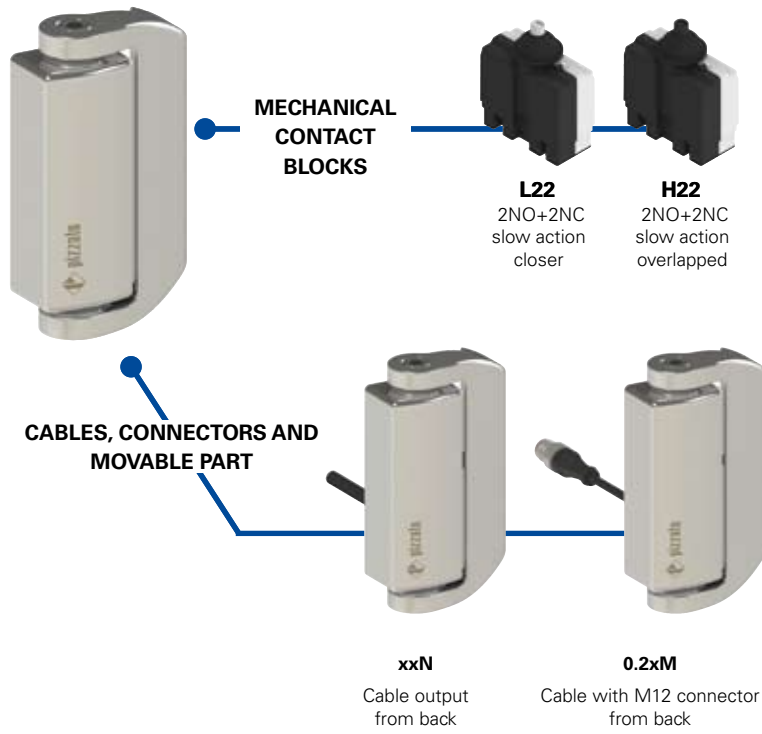

COMPLEMENTARY HINGES



HX CB

—●— product option

Code structure

Attention! The feasibility of a code number does not mean the effective availability of a product. Please contact our sales office.

HX BL22-2PN GH15

Body and movable part dimensions

B 126x76x31 mm

Contact block

L22	2NO+2NC, slow action closer
H22	2NO+2NC, slow action overlapped electronic contact block with LED
EE1	2 safety outputs PNP 1 auxiliary output PNP 2 safety inputs PNP

Type of connection

0.2	cable length 0.2 m
...
2	cable length 2 m (standard)
...
10	cable length 10 m

Other lengths on request.

Activation angle

	0° activation angle (standard)
H15	15° activation angle
H30	30° activation angle
H45	45° activation angle
H60	60° activation angle
H75	75° activation angle
H90	90° activation angle

Contacts type

	silver contacts (standard)
G	silver contacts gold plated 1 µm

Type of cable

N	cable PVC IEC 60332-1 black (standard)
M	cable with M12 connector

Connection outlet direction and movable part

P	rear cable outlet and movable part on the right
Q	rear cable outlet and movable part on the left

HX CB

Complementary hinges

CB	126x76x31 mm movable part on the right
CD	126x76x31 mm movable part on the left



Main data

- AISI 316L stainless steel housing
- Protection degree IP67 and IP69K
- Electronic contact block with LED
- Two mechanical contact blocks with positive opening \ominus
- Complementary hinges without contacts

In conformity with requirements requested by:

Low Voltage Directive 2006/95/EC,
Machinery Directive 2006/42/EC
Electromagnetic Compatibility 2004/108/EC

Positive contact opening in conformity with standards:

IEC 60947-5-1, EN 60947-5-1, VDE 0660-206.

In conformity with requirements requested by:

IEC 60947-5-1, EN 60947-5-1, EN 60947-1,
IEC 60204-1, EN 60204-1, EN 1088, ISO 14119,
EN ISO 12100-1, EN ISO 12100-2, IEC 60529,
EN 60529, DIN 40050, IEC 61508-1,
IEC 61508-2, IEC 61508-3, EN ISO 13849-1,
EN ISO 13849-2, EN 62061, EN 61326-1,
EN 61326-3-1, EN 61326-3-2

Markings and quality marks:



UL approvals pending
TÜV approvals pending
GOST approvals: POCC IT.AB24.B04512

Technical data

Housing

Metal housing, polished in AISI 316L stainless steel
Version with cable integrated length 2 m, other lengths on request.

Versions with cable and M12 8-pole male connector

Protection degree:

IP67 according to EN 60529
IP69K according to DIN 40050

(Protect the cables from direct high-pressure and high-temperature jets)

General data

For safety applications up to SIL 3 / PL e

Safety parameters:

B10: 1.000.000

B10_d: 5.000.000

B10/ B10_d: 20%

see table on page 6

600 operations cycles¹/hour

1 million operations cycles¹

Ambient temperature:

Max actuation frequency:

Mechanical endurance:

Max actuating speed:

Min. actuating speed:

Assembling position:

Max axial charge:

Max radial charge:

M6 screws max driving torque:

90°/s

2°/s

any

1500 N (preliminary data)

1000 N (preliminary data)

10 ... 12 Nm

(1) One operation cycle means two movements, one to close and one to open contacts, as foreseen by IEC 60947-5-1 standard.

Electrical data (L22 - H22 mechanical contact blocks)

Rated impulse withstand voltage U_{imp}:

4 kV

Conditional short circuit current:

1000 A according to EN 60947-5-1

Pollution degree:

3

Electrical data (EE1 electronic contact block)

Rated operational voltage U_e:

24 Vdc -15%...+10%

Rated operational current I_e:

0,25 A

Minimum working current:

0,5 mA

Maximum switchable load:

6 W

Voltage absorption (U_e):

< 1W

Rated impulse withstand voltage U_{imp}:

1,5 kV

Restorable internal protection fuse:

0,75 A

Overvoltage category:

III

Inputs IS1/IS2

Rated operational voltage U_e:

24 Vdc

Absorbed rated current:

5 mA

Safety outputs OS1/OS2

Rated operational voltage U_e:

24 Vdc

Type of output:

PNP

Maximum current for output I_e:

0,25 A

Short-circuit detection:

Yes

Protection against overcurrent:

Yes

Time of deactivation impulses on safe outputs: < 300 us

Capacity admitted between output and output: < 200 nF

Capacity admitted between output and earth: < 200 nF

Auxiliary output O3

Rated operational voltage U_e:

24 Vdc

Type of output:

PNP

Maximum current for output I_e:

0,1 A

Short-circuit detection:

No

Protection against overcurrent:

Yes

⚠ If not expressly indicated in this chapter, for the right installation and the correct utilization of all articles see requirements indicated from page 7/1 to page 7/10 of the general catalog.

⚠ Attention: switch off the circuit voltage before disconnecting the connector from the switch. The connector is not suitable for sectioning of electrical loads. According to EN 60204-1, versions with 8 poles M12 connector can be used only in circuits PELV.

Working temperatures and electrical data for L22 / H22 mechanical contact blocks

		Cable type N 9x0,34 mm ²	8 poles M12 connector	
Utilization temperatures	Fixed laying cable	-25°C ... +80°C	-25°C ... +80°C	
	Flexible laying cable	-5°C ... +80°C	-5°C ... +80°C	
	Dynamic laying cable	/	/	
Electrical data	Thermal current I _{th}	3 A	2 A	
	Rated insulation voltage U _i	250 Vac	30 Vac 36 Vdc	
	Protection against short circuits (fuse)	3 A 500 V type gG	2 A 500V type gG	
	Utilization categories DC13	24 V	2 A	2 A
		125 V	0,4 A	/
		250 V	0,3 A	/
	Utilization categories AC15	24 V	3 A	2 A
120 V		3 A	/	
250 V		3 A	/	

Working temperatures and electrical data for EE1 electronic contact block

		Cable type N 8x0,34 mm ²	8 poles M12 connector
Utilization temperatures	Fixed laying cable	-25°C ... +70°C	-25°C ... +70°C
	Flexible laying cable	-5°C ... +70°C	-5°C ... +70°C
	Dynamic laying cable	/	/
Electrical data	Thermal current I _{th}	0,25 A	0,25 A
	Rated insulation voltage U _i	32 Vdc	32 Vdc
	Protection against short circuits (fuse)	1 A	1 A
	Utilization categories DC12	24 V	0,25 A

Dimensional drawings

Contacts type:		Version with rear cable (2 m)	Version with rear cable (0.2 m) and M12 connector	Additional hinge without contact block		
LO = slow action overlapped LA = slow action closer = electronic PNP						
Contact blocks						
L22	LA	HX BL22-2PN	2NO+2NC	HX BL22-0.2PM	2NO+2NC	HX CB
H22	LO	HX BH22-2PN	2NO+2NC	HX BH22-0.2PM	2NO+2NC	
EE1		HX BEE1-2PN	PNP	HX BEE1-0.2PM	PNP	
Min. force		0,3 Nm (0,65 Nm)		0,3 Nm (0,65 Nm)		

To purchase a product with a movable part on the left replace letter P with letter Q in the codes mentioned above.
 Example: HX BL22-2PN → HX BL22-2QN

Internal connections

L22 / H22 mechanical contact blocks

Version with rear cable or M12 connector

connections	cable color	pin
NC	black	1
	black-white	2
	red	3
NC	red-white	4
	brown	5
NO	blue	6
	violet	7
NO	violet-white	8
	yellow-green	/

EE1 electronic contact block

Version with rear cable or M12 connector

connections	cable color	pin
A1	brown	1
IS1	red	2
A2	blue	3
OS1	red/white	4
O3	black	5
IS2	purple	6
OS2	black/white	7
not connected	purple/white	8

Legend

A1-A2	power supply
IS1-IS2	safety inputs
OS1-OS2	safety outputs
O3	auxiliary output

Travel diagrams

All measures in the diagrams are in degrees

Contact blocks	Group 1
L22 2NO+2NC	
H22 2NO+2NC	
EE1 PNP	

Legend

	Contact closed / OS1, OS2, O3 outputs active
	Contact open / OS1, OS2, O3 outputs not active
	Positive opening stroke

The contact operating point indicated in the stroke diagrams can be adjusted to ± 1°.

Accessories

Article	Description
VF AC7032	Protection plug of regulation screw
	The plug is supplied with every hinge and must always be inserted after the operating point regulation. In case of loss or damage, the plug can be ordered separately.



General catalog



Production program



ATEX brochure



LIFT
General Catalog



Dvd



Web site
www.pizzato.com



pizzato elettrica

Passion for Quality

Pizzato Elettrica s.r.l. Via Torino, 1 - 36063 Marostica (VI) Italy
Phone +39.0424.470.930 - Fax +39.0424.470.955
E-mail: info@pizzato.com - Web site: www.pizzato.com

ZE FGL13A13-ENG



8 018851 251214