

Selection diagram

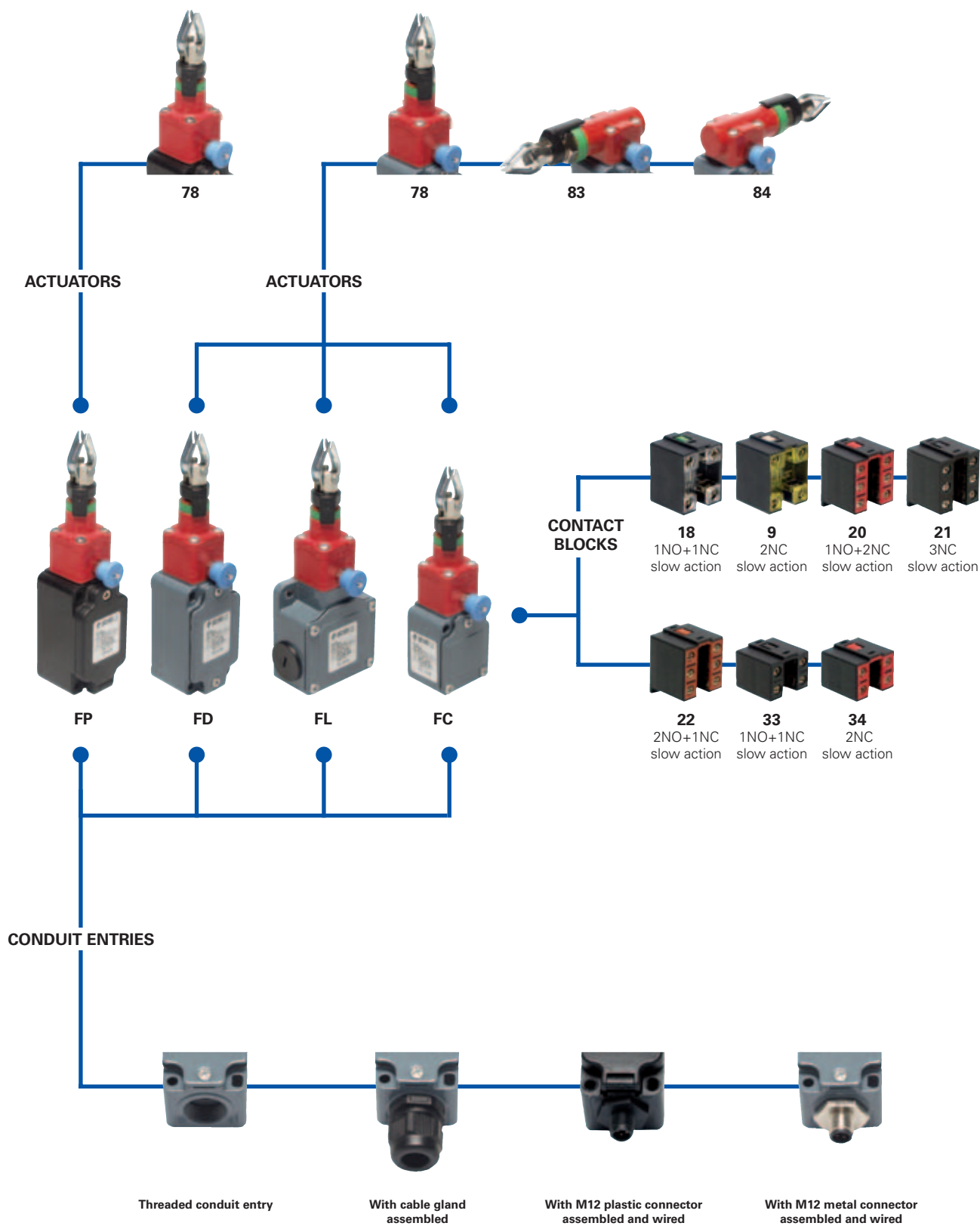

● product option  
 → accessory sold separately



## Code structure

**Attention!** The feasibility of a code number does not mean the effective availability of a product. Please contact our sales office.

# article options **FD 1878-GM2K50**

Housing	
<b>FD</b>	metal housing, one conduit entry
<b>FL</b>	metal housing, three conduit entries
<b>FP</b>	polymer housing, one conduit entry

Contact blocks	
<b>18</b>	1NO+1NC, slow action
<b>9</b>	2NC, slow action
<b>20</b>	1NO+2NC, slow action
<b>21</b>	3NC, slow action
<b>22</b>	2NO+1NC, slow action
<b>33</b>	1NO+1NC, slow action
<b>34</b>	2NC, slow action

Actuating head	
<b>78</b>	longitudinal head
<b>83</b>	left transversal head (FD-FL housing only)
<b>84</b>	right transversal head (FD-FL housing only)

Preinstalled cable gland or connectors	
	no cable gland or connector (standard)
<b>K21</b>	with assembled cable gland suitable for Ø 6 to Ø 12 mm cables range
...	.....
<b>K50</b>	with 5 poles M12 metal connector
...	.....

For the complete list of all combinations, please contact our technical office.

Threaded conduit entry	
	PG 13,5 (standard)
<b>M2</b>	M20x1,5

Contacts type	
	silver contacts (standard)
<b>G</b>	silver contacts gold plated 1 µm

# article options **FC 3378-GM1K22**

Housing	
<b>FC</b>	metal housing, one conduit entry

Contact blocks	
<b>33</b>	1NO+1NC, slow action
<b>34</b>	2NC, slow action

Actuating head	
<b>78</b>	longitudinal head
<b>83</b>	left transversal head
<b>84</b>	right transversal head

Preinstalled cable gland	
	no cable gland (standard)
<b>K22</b>	with assembled cable gland suitable for Ø 5 to Ø 10 mm cables range
<b>K26</b>	with assembled cable gland suitable for Ø 3 to Ø 7 mm cables range

Threaded conduit entry	
	PG 11 (standard)
<b>M1</b>	M16x1,5

Contacts type	
	silver contacts (standard)
<b>G</b>	silver contacts gold plated 1 µm

1  
1A  
1B  
2  
2A  
2B  
2C  
2D  
2E  
3  
3A  
3B  
3C  
4  
4A  
4B  
4C  
4D  
4E  
4F  
4G  
4H  
5  
6



### Main data

- Metal or polymer housing, from one to three conduit entries
- Protection degree IP67
- In conformity with EN ISO 13850
- 7 contact blocks available
- Transversal head or longitudinal head versions
- M12 assembled connector versions
- Silver contacts gold plated versions
- Several accessories available

### Markings and quality marks:



Approval IMQ:	EG605 (FD-FLFC series) EG606 (FP series)
Approval UL:	E131787
Approval CCC:	2007010305230000 (FD-FLFC series) 2007010305230014 (FP series)
Approval ECU:	1010151

### Technical data

#### Housing

Housing type FP made of glass-reinforced polymer, self-extinguishing, shock-proof thermoplastic resin with double insulation □

Housing type FD and FC made of metal, coated with baked epoxy powder.

FD, FP and FC series one conduit entry

FL series three conduit entries

Protection degree:

IP67 according to EN 60529

#### General data

Safety parameters:

see page 6/32

Ambient temperature:

from -25°C to +80°C

Version for operation in ambient temperature from -40°C to +80°C on request

Max operating frequency:

1 operation cycles / 6 s

Mechanical endurance:

1 million of operations cycles<sup>1</sup>

Max actuating speed:

0,5 m/s

Min. actuating speed:

1 mm/s

Driving torque for installation:

see pages 6/1-6/10

(1) One operation cycle means two movements, one to close and one to open contacts, as foreseen by EN 60947-5-1 standard.

#### Cross section of the conductors (flexible copper wire)

Contact blocks 20, 21, 22, 33, 34:

min. 1 x 0,34 mm<sup>2</sup> (1 x AWG 22)

max. 2 x 1,5 mm<sup>2</sup> (2 x AWG 16)

Contact blocks 18, 9:

min. 1 x 0,5 mm<sup>2</sup> (1 x AWG 20)

max. 2 x 2,5 mm<sup>2</sup> (2 x AWG 14)

#### In conformity with standards:

IEC 60947-5-1, EN 60947-5-1, IEC 60204-1, EN 60204-1, EN 1088, EN ISO 12100-1, EN ISO 12100-2, IEC 60529, EN 60529, EN ISO 13850, EN 418, NFC 63-140, VDE 0660-200, VDE 0113, CENELEC EN 50013.

#### Approvals:

IEC 60947-5-1, UL 508, GB14048.5-2001

#### In conformity with requirements requested by:

Low Voltage Directive 2006/95/EC, Machinery Directive 2006/42/EC and Electromagnetic Compatibility 2004/108/EC.

#### Positive contact opening in conformity with standards:

IEC 60947-5-1, EN 60947-5-1, VDE 0660-206.

⚠ If not expressly indicated in this chapter, for the right installation and the correct utilization of all articles see requirements indicated from page 6/1 to page 6/10.

#### Electrical data

#### Utilization categories

without connector	Thermal current (I <sub>th</sub> ):	10 A	Alternate current: AC15 (50...60 Hz)			
	Rated insulation voltage (U <sub>i</sub> ):	500 Vac 600 Vdc	U <sub>e</sub> (V)	250	400	500
		400 Vac 500 Vdc	I <sub>e</sub> (A)	6	4	1
	for contact blocks 20, 21, 22, 33, 34		Direct current: DC13			
Conditional short circuit current:	1000 A according to EN 60947-5-1	U <sub>e</sub> (V)	24	125	250	
Protection against short circuits:	fuse 10 A 500 V type aM	I <sub>e</sub> (A)	6	1,1	0,4	
Pollution degree:	3					

with 4 or 5 poles M12 connector	Thermal current (I <sub>th</sub> ):	4 A	Alternate current: AC15 (50...60 Hz)			
	Rated insulation voltage (U <sub>i</sub> ):	250 Vac 300 Vdc	U <sub>e</sub> (V)	24	120	250
		Protection against short circuits:	fuse 4 A 500 V type gG	I <sub>e</sub> (A)	4	4
	Pollution degrees:	3	Direct current: DC13			
U <sub>e</sub> (V)	24	125	250			
I <sub>e</sub> (A)	4	1,1	0,4			

with 8 poles M12 connector	Thermal current (I <sub>th</sub> ):	2 A	Alternate current: AC15 (50...60 Hz)		
	Rated insulation voltage (U <sub>i</sub> ):	30 Vac 36 Vdc	U <sub>e</sub> (V)	24	
		Protection against short circuits:	fuse 2 A 500 V type gG	I <sub>e</sub> (A)	2
	Pollution degrees:	3	Direct current: DC13		
U <sub>e</sub> (V)	24				
I <sub>e</sub> (A)	2				



## Description

These rope operated safety switches are installed on machines or conveyor belts, to activate the emergency stop of the machine on every hand intervention on the rope, from any point. They allow cost savings on machines of medium-large size, where normally many emergency stop push buttons can be replaced by one single switch. Provided with **self-control function**, they constantly check their correct working operation, signalling with the opening of the contacts an eventual loosening or breaking of the rope. These safety switches, after their activation, keep the contacts open till the reset push button is manually pulled, even if the rope is left free.

## Rotating heads

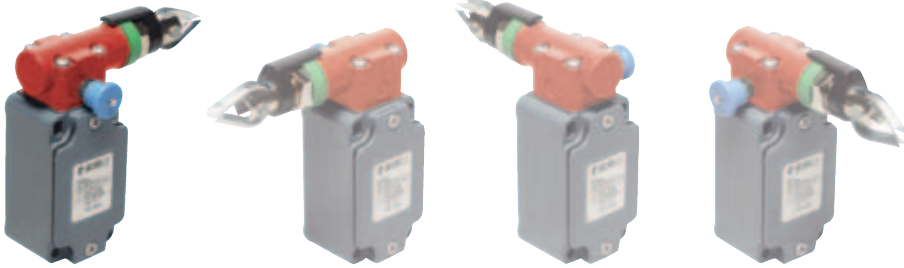

Removing the four fastening screws, in all switches, it is possible to rotate the head in 90° steps.

## Rope regulation point indicator

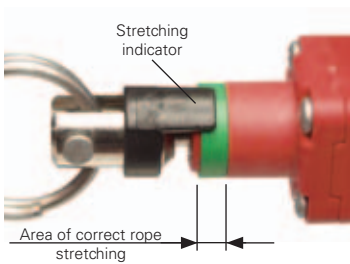

All switches are provided with a green ring that shows the area of the correct stretching of the rope. The installer has only to stretch the rope until the black indicator will be in the middle of the green area. In this position it is possible to reset the switch, pulling the reset button, and to close the electrical safety contacts.

If a traction (or loosening) of the rope it is high enough to permit the black indicator to go outside the correct stretching area, there will be the reset action and the opening of the safety contacts.

## Reset button indicator



If the rope stretching indicator is in the correct operation area, it is possible to close the electric safety contacts pulling the blue reset button. The green ring signal allows to know the switch condition quickly.

## Data type approved by IMQ, CCC and EZU

Rated insulation voltage (Ui): 500 Vac  
400 Vac for contact blocks 20, 21, 22, 33, 34  
Thermal current (Ith): 10 A  
Protection against short circuits: fuse 10 A 500 V type aM  
Protection degree: IP67  
MV terminals (screw clamps)  
Pollution degrees 3  
Utilization category: AC15  
Operation voltage (Ue): 400 Vac (50 Hz)  
Operation current (Ie): 3 A  
Forms of the contact element: Zb, Y+Y, Y+Y+X, Y+Y+Y, Y+X+X  
Positive opening of contacts on contact block 18, 9, 20, 21, 22, 33, 34

In conformity with standards: EN 60947-1, EN 60947-5-1 and subsequent modifications and completions, fundamental requirements of the Low Voltage Directive 2006/95/CE and subsequent modifications and completions.

Please contact our technical service for the list of approved products.

## Data type approved by UL

Utilization categories Q300 (69 VA, 125-250 Vdc)  
A600 (720 VA, 120-600 Vac)  
Data of the housing type 1, 4X "indoor use only", 12, 13  
For all contact blocks use 60 or 75 °C copper (Cu) conductor and wire size No. 12-14 AWG. Terminal tightening torque of 7,1 lb in (0.8 Nm).  
In conformity with standard: UL 508

Please contact our technical service for the list of approved products.

1  
1A  
1B  
2  
2A  
2B  
2C  
2D  
2E  
3  
3A  
3B  
3C  
4  
4A  
4B  
4C  
4D  
4E  
4F  
4G  
4H  
5  
6

Dimensional drawings

Contacts type:

= slow action

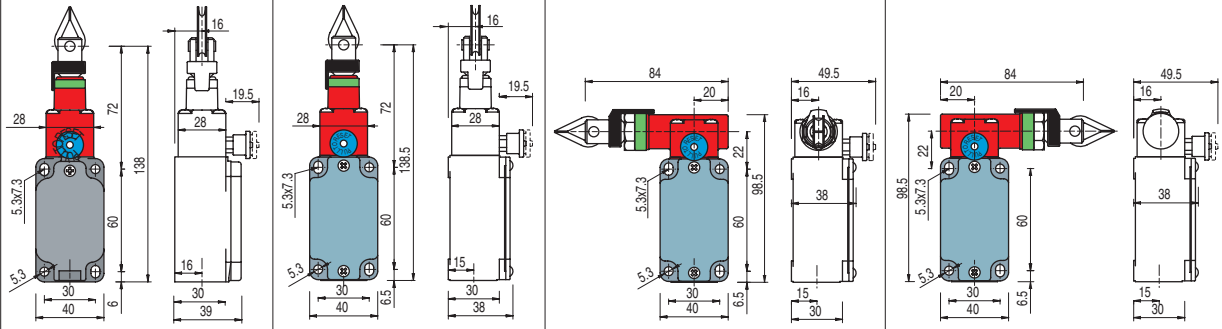

Contact blocks

18		<b>FP 1878</b>		1NO+1NC	<b>FD 1878</b>		1NO+1NC	<b>FD 1883</b>		1NO+1NC	<b>FD 1884</b>		1NO+1NC
9		FP 978		2NC	FD 978		2NC	FD 983		2NC	FD 984		2NC
20		FP 2078		1NO+2NC	FD 2078		1NO+2NC	FD 2083		1NO+2NC	FD 2084		1NO+2NC
21		FP 2178		3NC	FD 2178		3NC	FD 2183		3NC	FD 2184		3NC
22		FP 2278		2NO+1NC	FD 2278		2NO+1NC	FD 2283		2NO+1NC	FD 2284		2NO+1NC
33		FP 3378		1NO+1NC	FD 3378		1NO+1NC	FD 3383		1NO+1NC	FD 3384		1NO+1NC
34		FP 3478		2NC	FD 3478		2NC	FD 3483		2NC	FD 3484		2NC
Min. force		Initial 63 N...Final 83 N (90 N		Initial 63 N...Final 83 N (90 N		Initial 147 N...Final 235 N (250 N		Initial 147 N...Final 235 N (250 N		Initial 147 N...Final 235 N (250 N		Initial 147 N...Final 235 N (250 N	
Travel diagrams		page 4/106 - group 1		page 4/106 - group 1		page 4/106 - group 2		page 4/106 - group 2		page 4/106 - group 2		page 4/106 - group 2	

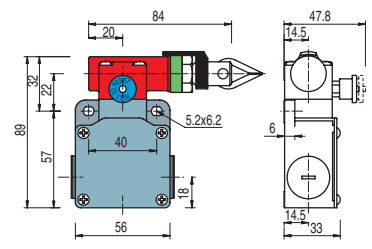
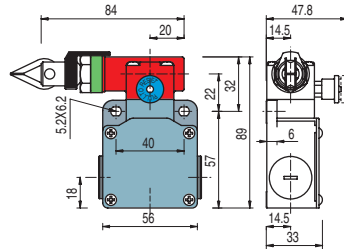
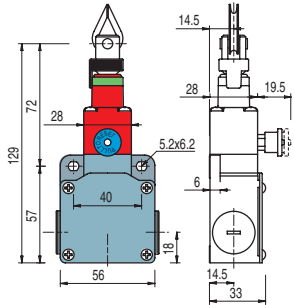

Contact blocks

18		<b>FL 1878</b>		1NO+1NC	<b>FL 1883</b>		1NO+1NC	<b>FL 1884</b>		1NO+1NC	
9		FL 978		2NC	FL 983		2NC	FL 984		2NC	
20		FL 2078		1NO+2NC	FL 2083		1NO+2NC	FL 2084		1NO+2NC	
21		FL 2178		3NC	FL 2183		3NC	FL 2184		3NC	
22		FL 2278		2NO+1NC	FL 2283		2NO+1NC	FL 2284		2NO+1NC	
33		FL 3378		1NO+1NC	FL 3383		1NO+1NC	FL 3384		1NO+1NC	
34		FL 3478		2NC	FL 3483		2NC	FL 3484		2NC	
Min. force		Initial 63 N...Final 83 N (90 N		Initial 147 N...Final 235 N (250 N		Initial 147 N...Final 235 N (250 N		Initial 147 N...Final 235 N (250 N		Initial 147 N...Final 235 N (250 N	
Travel diagrams		page 4/106 - group 1		page 4/106 - group 2		page 4/106 - group 2		page 4/106 - group 2		page 4/106 - group 2	



Contacts type:						
<b>L</b> = slow action						
Contact blocks	<b>33</b> <b>L</b> <b>FC 3378</b> $\ominus$ 1NO+1NC <b>34</b> <b>L</b> <b>FC 3478</b> $\ominus$ 2NC	<b>FC 3383</b> $\ominus$ 1NO+1NC <b>FC 3483</b> $\ominus$ 2NC	<b>FC 3384</b> $\ominus$ 1NO+1NC <b>FC 3484</b> $\ominus$ 2NC	Min. force Initial 63 N ... Final 83 N (90 N $\ominus$ ) Travel diagrams page 4/106 - group 1		
	Initial 147 N ... Final 235 N (250 N $\ominus$ ) page 4/106 - group 2		Initial 147 N ... Final 235 N (250 N $\ominus$ ) page 4/106 - group 2			

### How to read travel diagrams

All measures in the diagrams are in mm

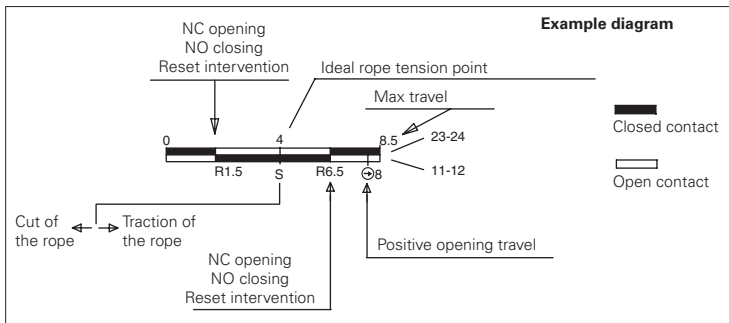

### Travel diagrams table

Contact blocks	Group 1	Group 2
18 1NO+1NC		
9 2NC		
20 1NO+2NC		
21 3NC		
22 2NO+1NC		
33 1NC+1NO		
34 2NC		

#### IMPORTANT:

In safety applications it is necessary to activate the switch **at least up to the positive opening point** indicated in the diagrams with the symbol  $\ominus$ . Operate the switch **at least with the positive opening force**, indicated between brackets, below each article, next the value of minimum force.

Items with code on the **green** background are available in stock

Application examples and max rope length for switches with longitudinal heads

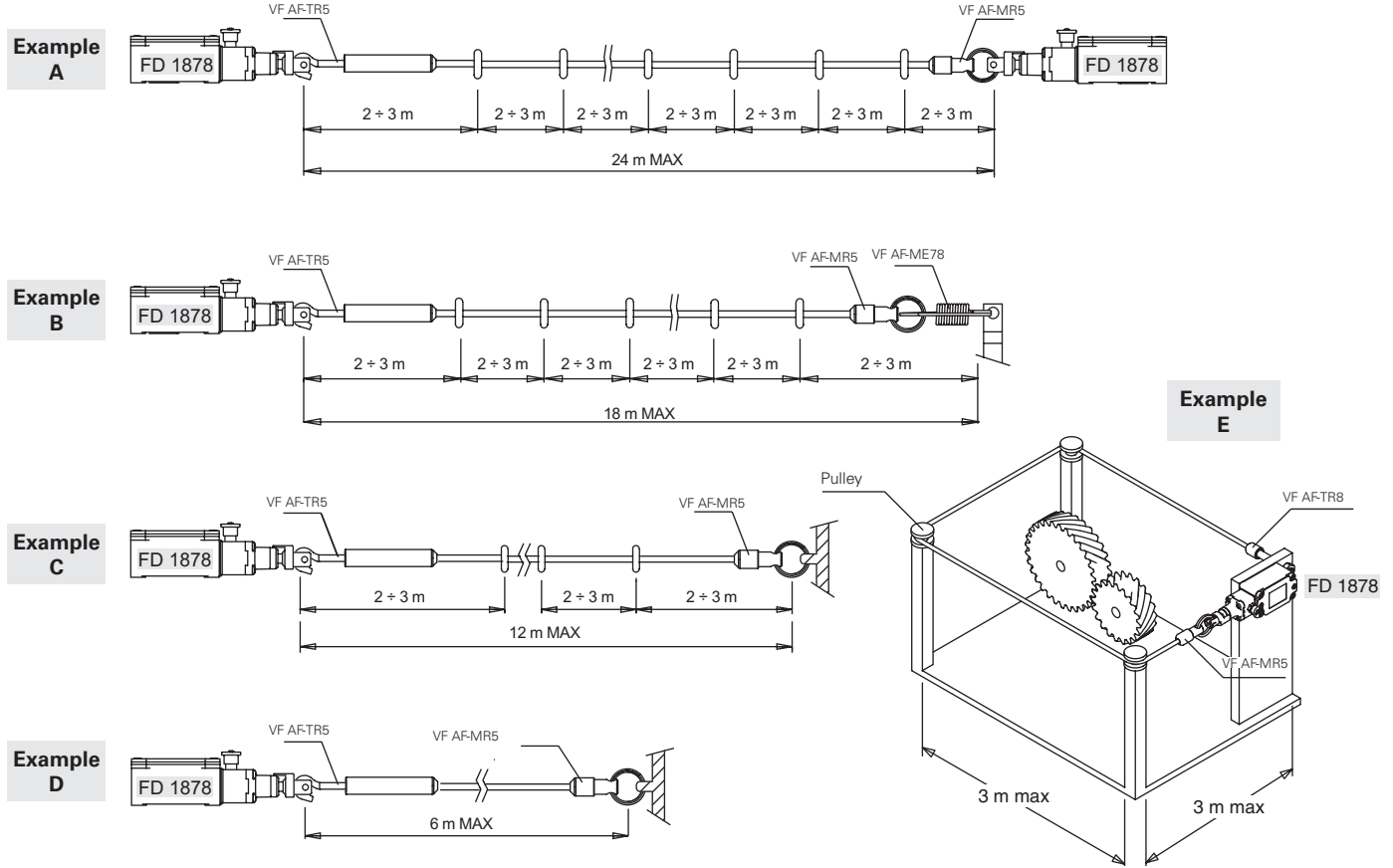

Application examples and max rope length for switches with transversal heads

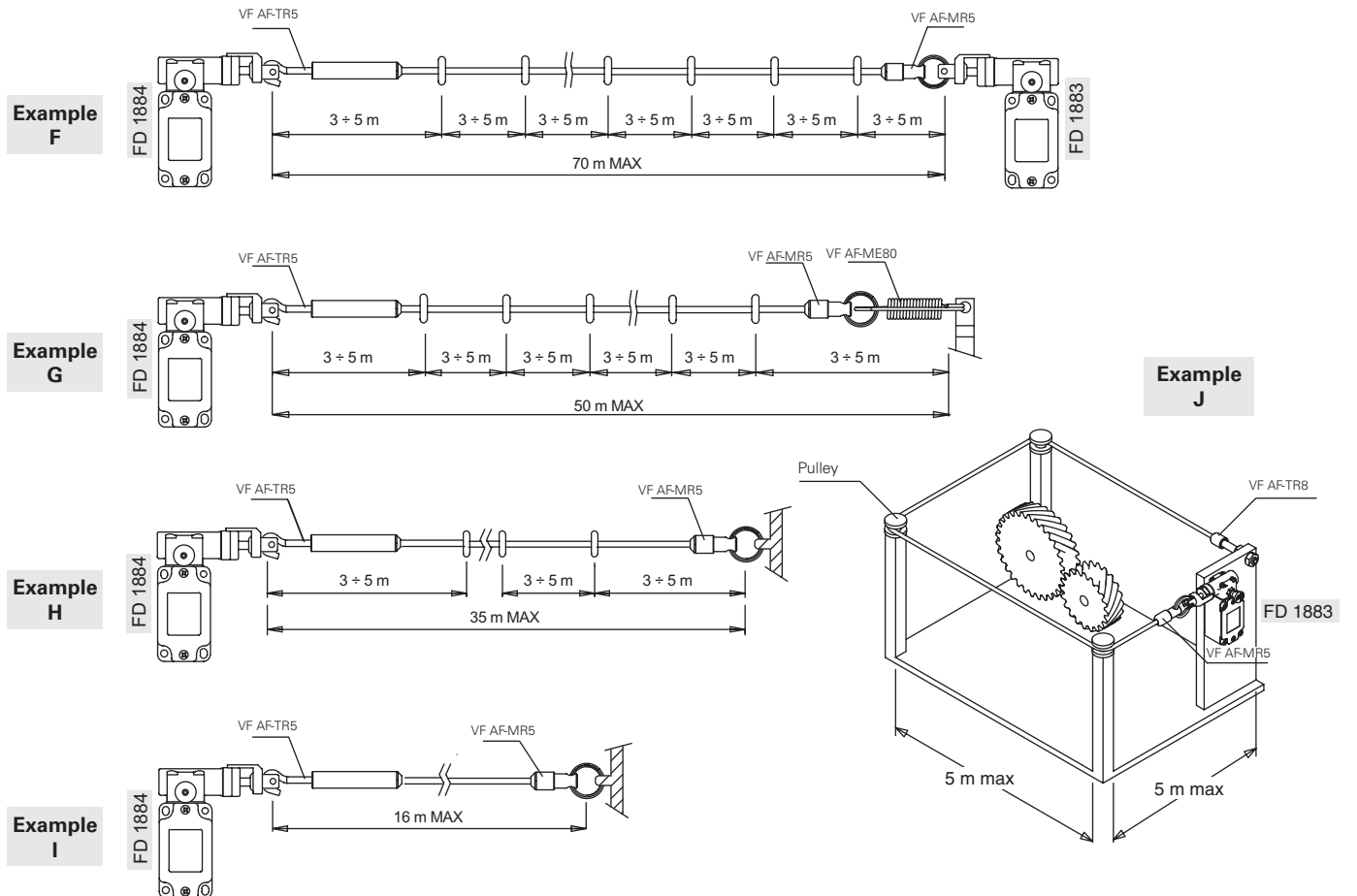



## Max rope length

Max rope length for switches with longitudinal heads

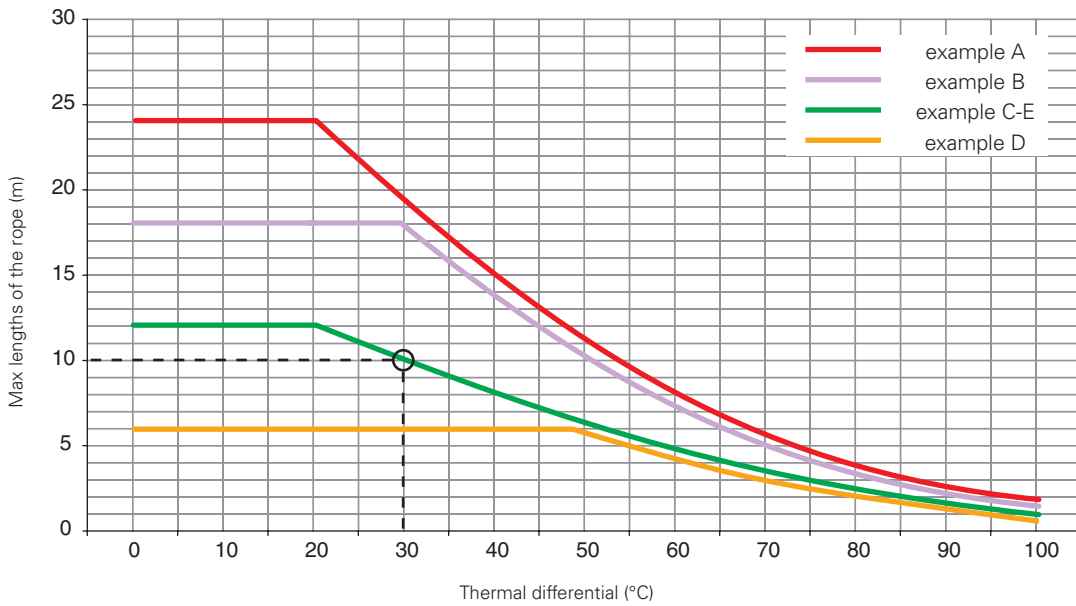

In the diagram, the suggested max. rope lengths with regard to changes of temperature (thermal differential) to which the switch is expected to be exposed in the working area are indicated. For instance, for an example C installation which expects a thermal differential of 30°C, a max rope length of 10 meters is suggested.

Max rope length for switches with transversal heads

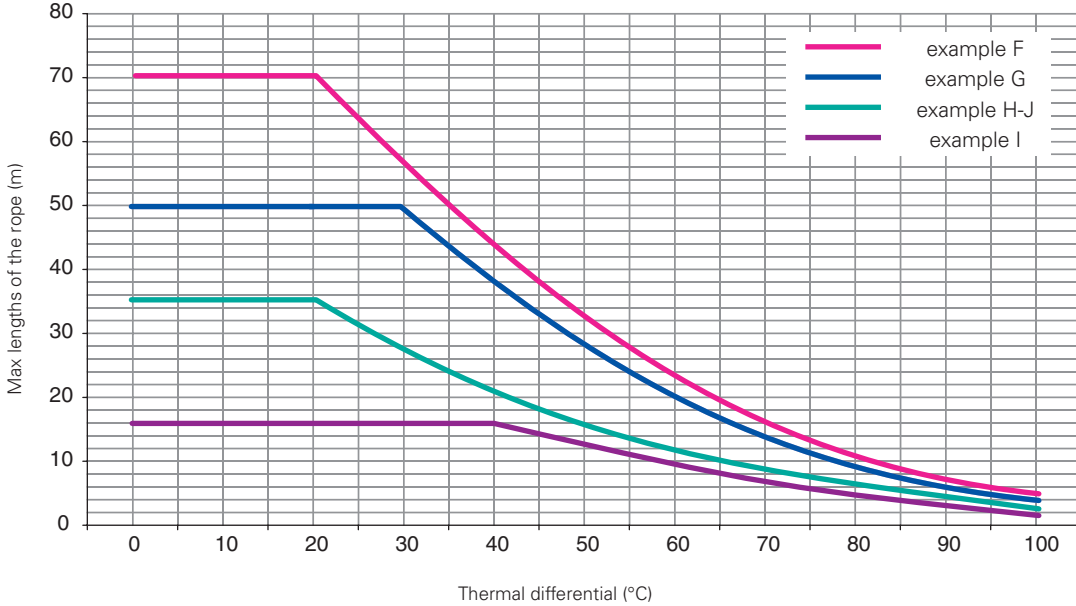

Important: The above data are guaranteed only using original rope and accessories. See page 4/117.

## Regulation of intervention point

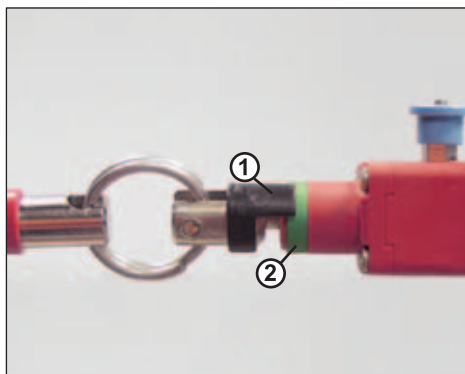

Stretch the rope connected to the switch, until the end of the indicator (1) reaches about the middle of the green ring (2).

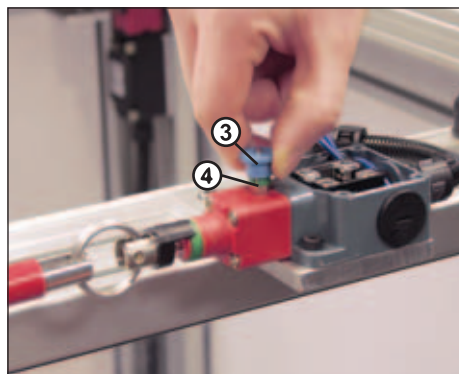

Pull the knob (3) in order to close the safety contacts inside the switch. Below the knob a green ring (4) will be disclosed.

1  
1A  
1B  
2  
2A  
2B  
2C  
2D  
2E  
3  
3A  
3B  
3C  
4  
4A  
4B  
4C  
4D  
4E  
4F  
4G  
4H  
5  
6